



Effiziente Schnellmontage
in 45 Minuten einsatzbereit



Kompaktes Kraftpaket
bis 1,8t Hublast



Leiser Betrieb
elektrischer Anschluss



Hohe Arbeitssicherheit
präzise Funkfernsteuerung



Flexibel einsetzbar
Platzbedarf 4,2 x 4,2 m

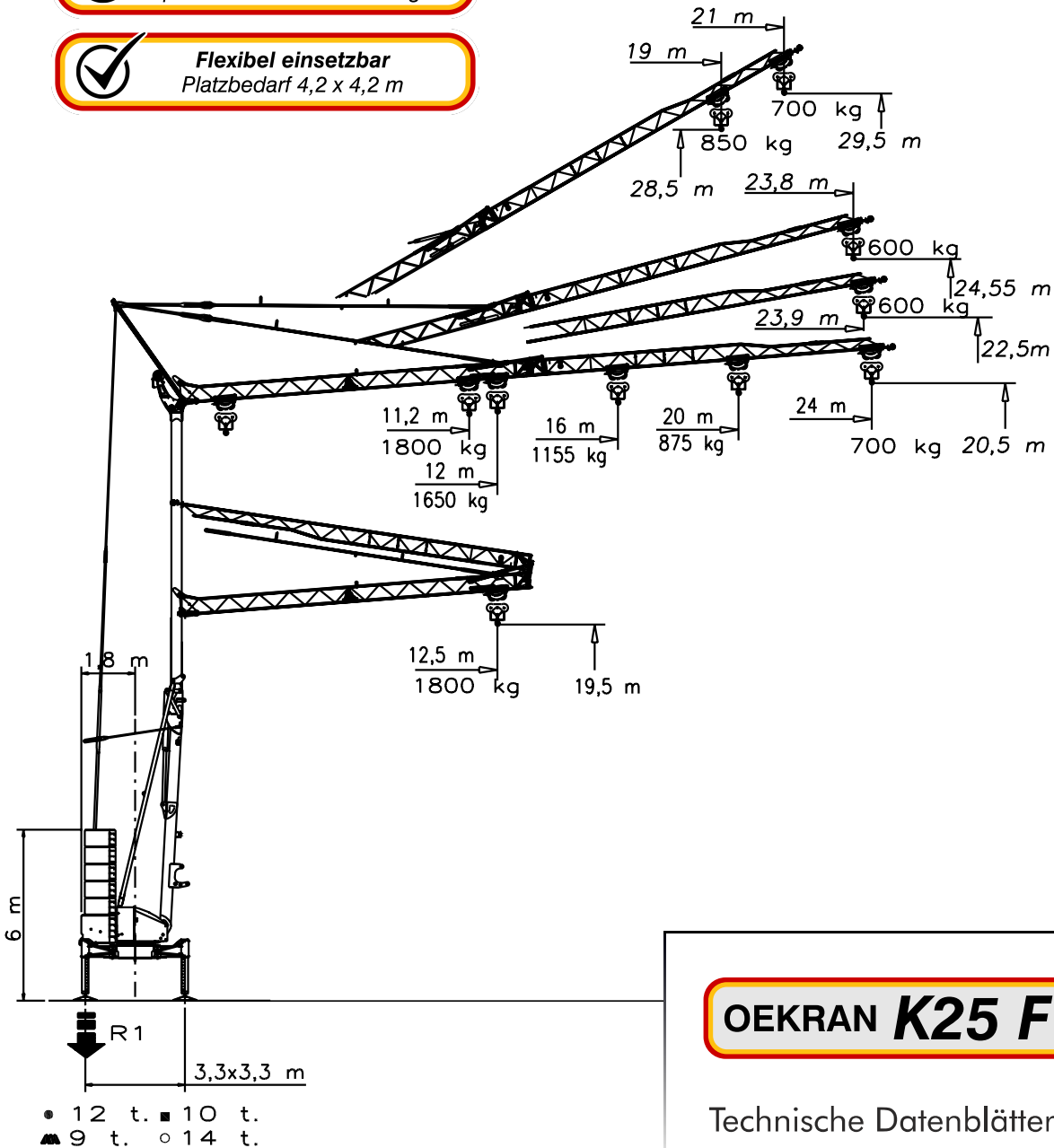

OEKRAN K25 F

Technische Datenblätter

Lastkurven | Courbes de charges | Load diagrams | Curve di carico | Curvas de cargas

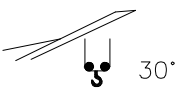
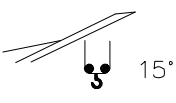
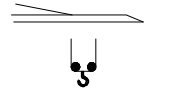
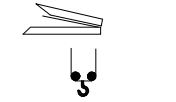
	<table border="1"> <tr> <td>3</td> <td>19</td> <td>21</td> <td>m</td> </tr> <tr> <td>1800</td> <td>850</td> <td>700</td> <td>kg</td> </tr> </table>	3	19	21	m	1800	850	700	kg						
3	19	21	m												
1800	850	700	kg												
	<table border="1"> <tr> <td>3</td> <td>22</td> <td>23,8</td> <td>m</td> </tr> <tr> <td>600</td> <td>600</td> <td>600</td> <td>kg</td> </tr> </table>	3	22	23,8	m	600	600	600	kg						
3	22	23,8	m												
600	600	600	kg												
	<table border="1"> <tr> <td>3</td> <td>11,2</td> <td>12</td> <td>16</td> <td>20</td> <td>24</td> <td>m</td> </tr> <tr> <td>1800</td> <td>1800</td> <td>1650</td> <td>1155</td> <td>875</td> <td>700</td> <td>kg</td> </tr> </table>	3	11,2	12	16	20	24	m	1800	1800	1650	1155	875	700	kg
3	11,2	12	16	20	24	m									
1800	1800	1650	1155	875	700	kg									
	<table border="1"> <tr> <td>3</td> <td>12,5</td> <td>m</td> </tr> <tr> <td>1800</td> <td>1800</td> <td>kg</td> </tr> </table>	3	12,5	m	1800	1800	kg								
3	12,5	m													
1800	1800	kg													

Eckdrücke | Reactions | Réactions | Reazioni | Reacciones | Reacções

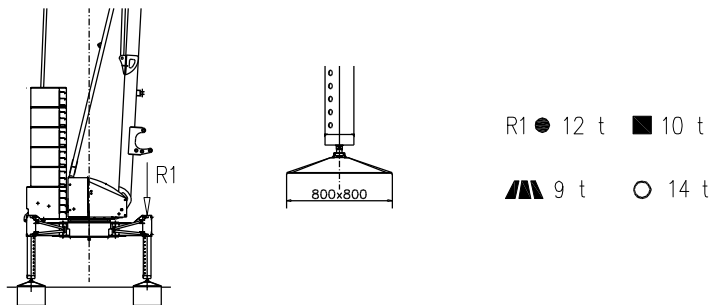

- Reaktionskräfte in Betrieb | Reazioni in servizio | Reactions in service | Réactions en service
Reacciones en servicio | Em serviço
- Reaktionskräfte außer Betrieb | Reazioni fuori servizio | Reactions out of service | Réactions hors service
Reacciones fuera de servicio | Fora de serviço
- ▲ Konstruktionsgewicht ohne Transportachse | Peso della gru senza assali | Dead weight without transport axles
Poids de construction sans eissieux | Peso de la grua sin tren de transporte | Peso de grua sem carro de transporte
- Ballastgewicht | Peso zavorra rotante | Ballast weight | Poids du lest
Peso de lastre | Peso de lastre rotativo

OEKRAN K25 F

Montage | Montage | Erection | Montaggio | Montaje | Montagem

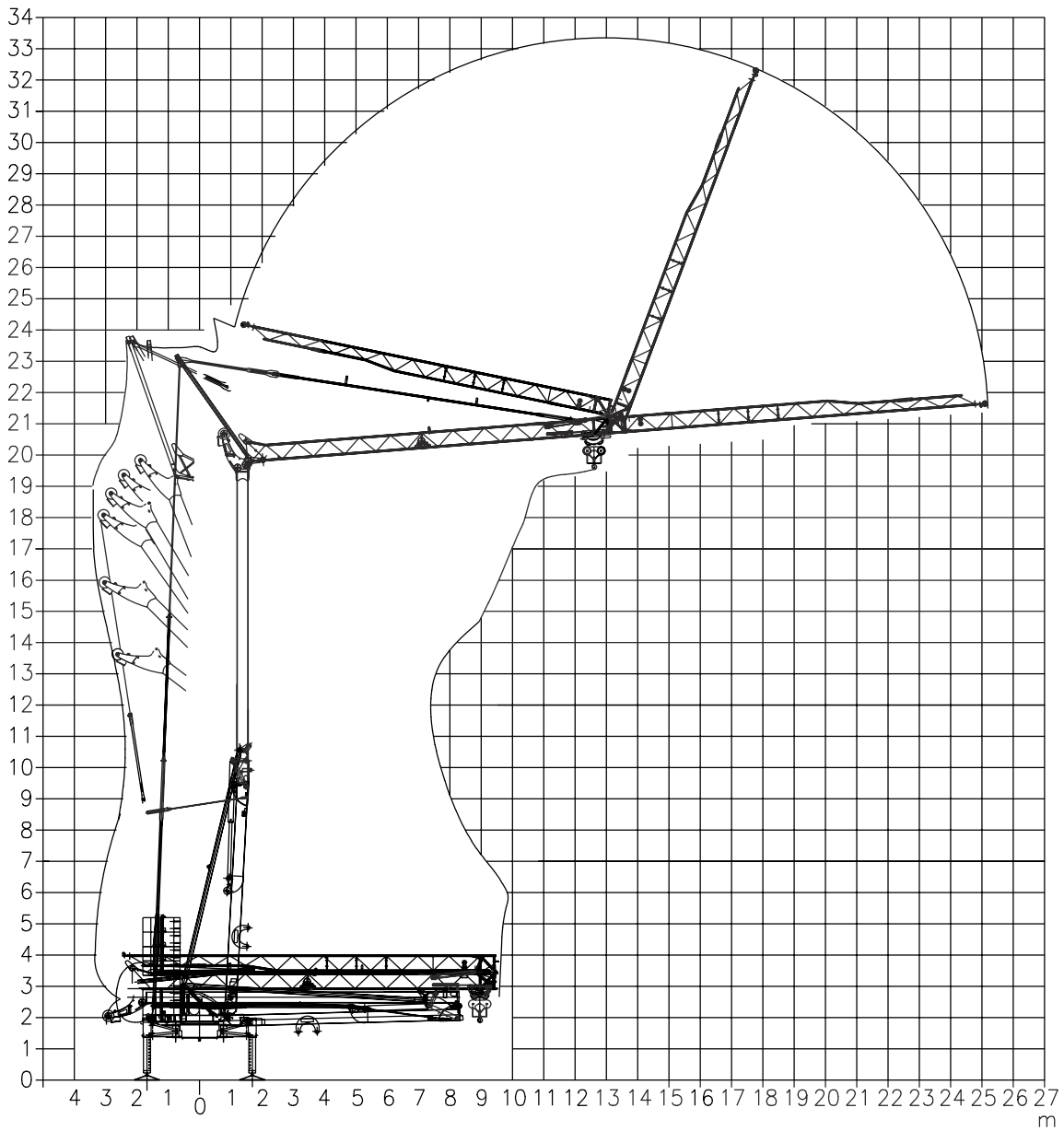

Transport | Transport | Transport | Trasporto | Transporte

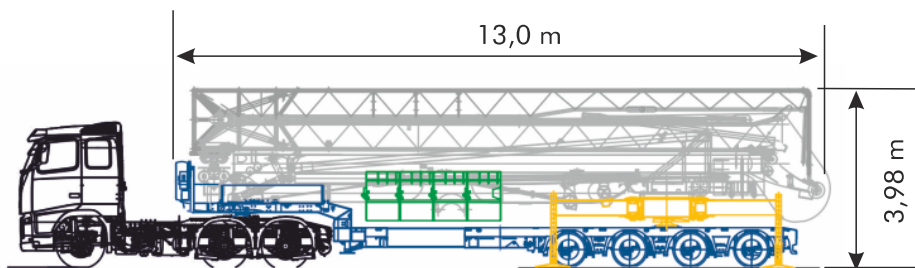

OEKRAN K25 F

Antriebe | Mechanisms | Mécanismes | Meccanismi | Mecanismos

V7,5.30 230 Volt Sollevamento Hoisting Levage Heben Elevaciòn Elevaçao						V7,5.30 5.5 kW (7.5 Hp) 2-11 kVA 	
	m/min	4	11	25			
	t	1.8	1.8	0.7			
		4	16	30			
		1.8	1.8	0.7			
V7,5.30 400 Volt Sollevamento Hoisting Levage Heben Elevaciòn Elevaçao						V7,5.30 5.5 kW (7.5 Hp) 11 kVA 	
	m/min	4	11	30			
	t	1.8	1.8	0.7			
		4	16	30			
		1.8	1.8	0.7			
Carrello Trolleying Distribuciòn Katzfahren Distribuiçao				2a	0 → 30	m/min	2.2 kW (Hp 3)
Rotazione Slewing Orientaciòn Schwenken Rotaçao				1a	0 → 0.8	giri/min tr/min rp/min	2.2 kW (Hp 3)
				2a			
				3a			

Rete elettrica | Réseau | Mains supply | Netzstrom | Red | Rede electrica

230/400 V - 50 Hz

Potenza elettrica necessaria | Puissance électrique nécessaire | Necessary electric power
Anschlusswert | Potencia electrica necesaria

1/3PH 2-11 kVA

FEM 1.001-A3 2000/14/CE



Documento commerciale non contrattuale
Per tutte le informazioni tecniche riferirsi
alle corrispondenti istruzioni

Unverbindliches Vertriebsdokument.
Für technische Informationen, siehe die
entsprechenden Anweisungen.

This commercial document is not legally
binding. For any technical information, please
refer to the corresponding instructions.

Documento commercial no contractual
Para cualquier información técnica,
ver la noticia correspondiente.

oekran.at

JTK ÖKran GmbH

Jahrings 66
3910 Zwettl
ATU 81363757

office@oekran.at
www.oekran.at
0670/1931616